

DESCRIPTION

The LM358 consists of two independent, high gain, internally frequency compensated operational amplifiers which were designed specifically to operate from a single power supply over a wide range of voltages. Operation from split power supplies is also possible and the low power supply current drain is independent of the magnitude of the power supply voltage.

Application areas include transducer amplifiers, dc gain blocks and all the conventional op amp circuits.

FEATURES

- Wide range of supply voltages
- Low supply current drain independent of supply voltage
- Low input biasing current
- Low input offset voltage and offset current
- Input common-mode voltage range includes ground
- Differential input voltage range equal to the power supply voltage
- DC voltage gain 100 V/ mV Typ
- Internally frequency compensation

PIN CONFIGURATION

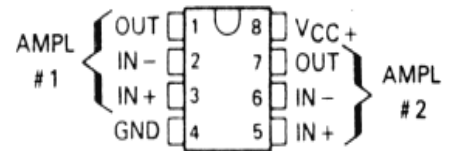

SYMBOL (each amplifier)

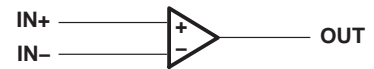

SCHEMATIC DIAGRAM

(each amplifier only)

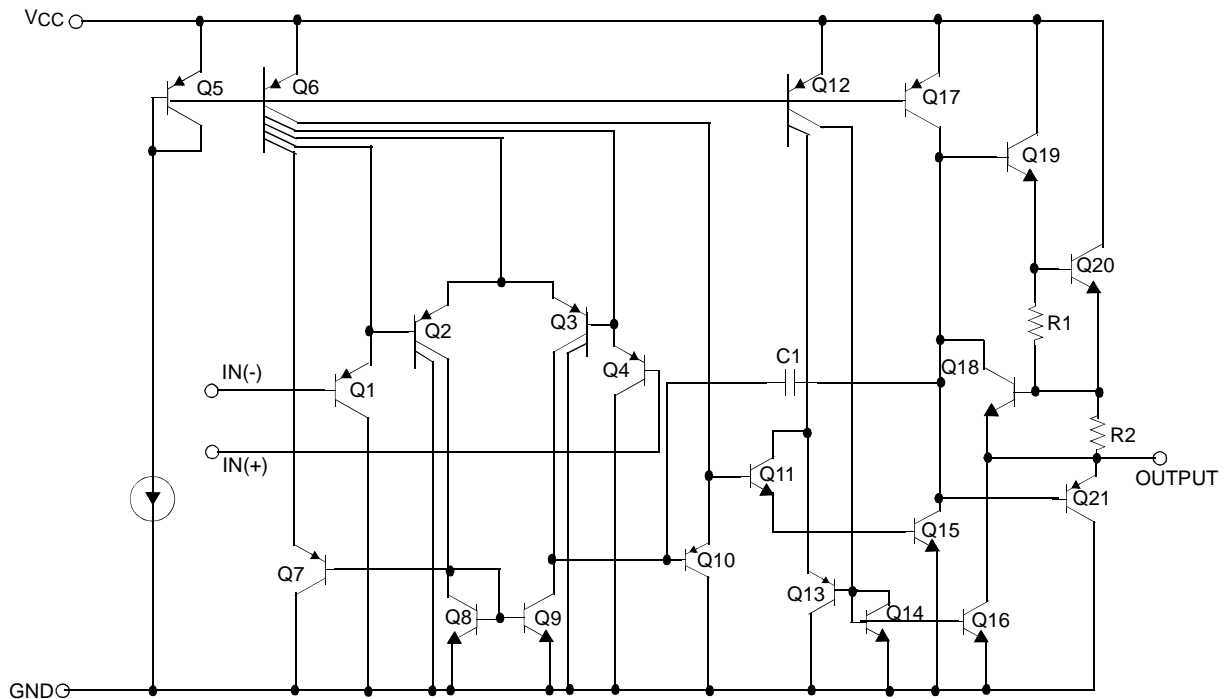

ABSOLUTE MAXIMUM RATINGS

Parameter	Symbol	LM358DR	Unit
Supply Voltage	V _{CC}	±16 or 32	V
Differential Input Voltage	V _{I(DIFF)}	32	V
Input Voltage	V _I	-0.3 to +32	V
Output Short Circuit to GND V _{CC} ≤ 15V, T _A = 25°C (One Amp)	-	Continuous	-
Operating Temperature Range	TOPR	0 ~ +70	°C
Storage Temperature Range	TSTG	-65 ~ +150	°C

ELECTRICAL CHARACTERISTICS

 at specified free-air temperature, V_{CC} = 5 V (unless otherwise noted)

PARAMETER	TEST CONDITIONS*	LM358DR			UNIT	
		MIN	TYP	MAX		
V _{IO} Input offset voltage	V _{CC} = 5 V to MAX, V _{IC} = V _{ICR} min, V _O = 1.4 V	25 °C	3	7	mV	
		Full range		9		
αV _{IO} Average temperature coefficient of input offset voltage		Full range	7		μV/°C	
I _{IO} Input offset current	V _O = 1.4 V	25 °C	2	50	nA	
		Full range		150		
αI _{IO} Average temperature coefficient of input offset current		Full range	10		pA/°C	
I _{IB} Input bias current	V _O = 1.4 V	25 °C	-20	-250	nA	
		Full range		-500		
V _{ICR} Common-mode input voltage range	V _{CC} = 5 V to MAX	25 °C	0 to V _{CC} -1.5		V	
		Full range	0 to V _{CC} - 2			
V _{OH} High-level output voltage	R _L ≥ 2 kΩ (NOTE 1)	25 °C	V _{CC} -1.5		V	
	V _{CC} = MAX, R _L = 2 kΩ	Full range	26			
	V _{CC} = MAX, R _L ≥ 10 kΩ	Full range	27	28		
V _{OL} Low-level output voltage	R _L ≥ 10 kΩ	Full range		5	20	mV
A _{VD} Large-signal differential voltage amplification	V _{CC} = 15 V, V _O = 1V to 11 V, R _L ≥ 2 kΩ	25 °C	25	100	V/mV	
		Full range	15			
CMRR Common-mode rejection ratio	V _{CC} = 5 V to MAX, V _{IC} = V _{ICR} min	25 °C	65	80	dB	
k _{SVR} Supply voltage rejection ratio (ΔV _{CC} /ΔV _{IO})	V _{CC} = 5 V to MAX	25 °C	65	100	dB	
V _{O1} / V _{O2} Crosstalk attenuation	f = 1 kHz to 20 kHz	25 °C		120	dB	
I _O Output current	V _{CC} = 15 V, V _{ID} = 1 V, V _O = 0	25 °C	-20	-30	mA	
		Full range	-10			
	V _{CC} = 15 V, V _{ID} = -1 V, V _O = 15 V	25 °C	10	20		
		Full range	5			
V _{ID} = -1 V, V _O = 200 mV	25 °C	12	30	μA		
I _{OS} Short-circuit output current	V _{CC} at 5 V, GND at -5 V, V _O = 0	25 °C		±40	±60	mA
I _{CC} Supply current (two amplifiers)	V _O = 2.5 V, No load	Full range		0.7	1.2	mA
	V _{CC} = MAX, V _O = 0.5V _{CC} , No load	Full range		1	2	

- All characteristics are measured under open-loop conditions with zero common-mode input voltage unless otherwise specified. "MAX" V_{CC} for testing purposes is 30 V. Full range is 0 °C to 70 °C.

MECHANICAL DIMENSION

D PLASTIC SMALL-OUTLINE PACKAGE

8 PINS SHOWN

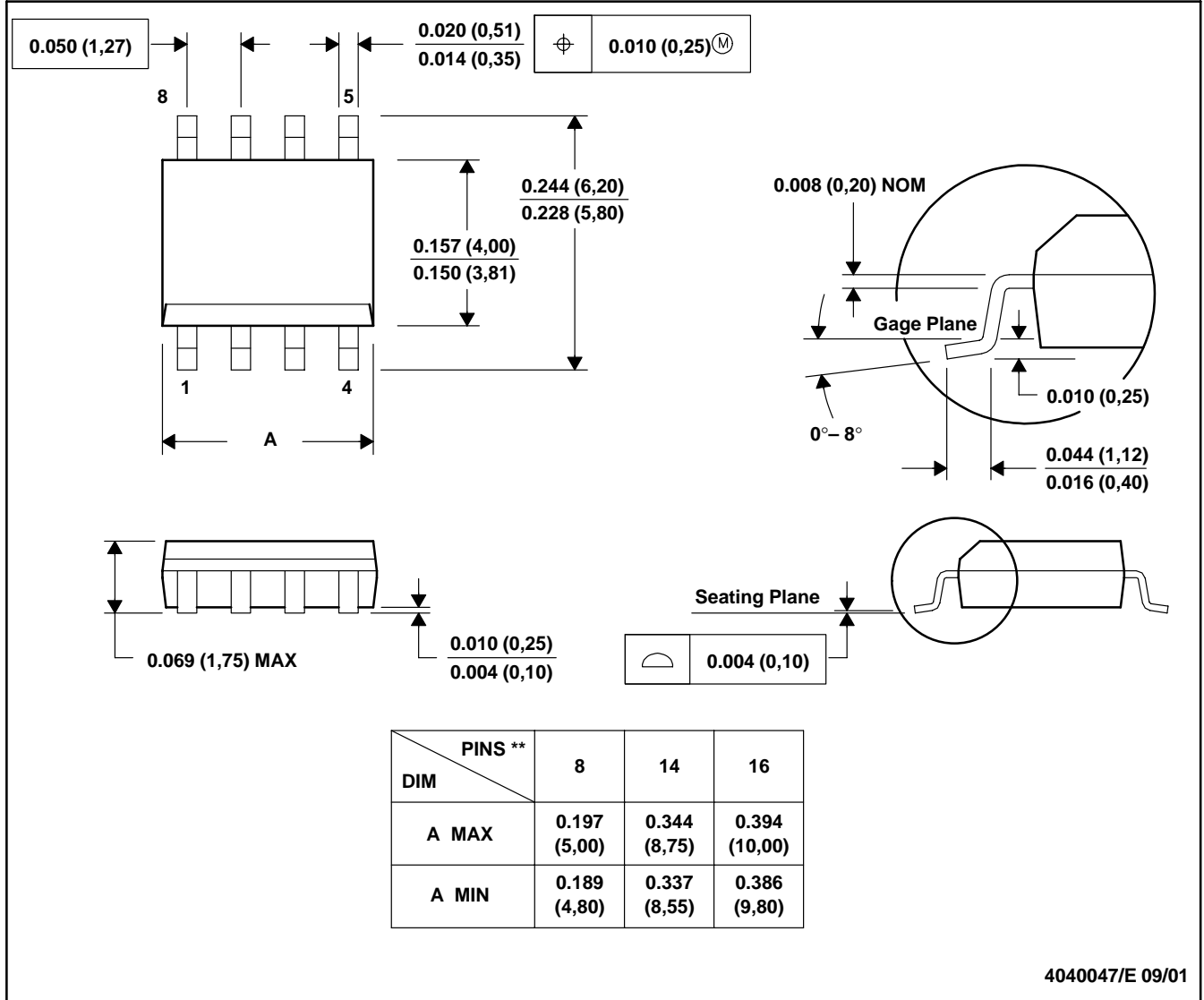

- NOTES: A. All linear dimensions are in inches (millimeters).
 B. This drawing is subject to change without notice.
 C. Body dimensions do not include mold flash or protrusion, not to exceed 0.006 (0,15).
 D. Falls within JEDEC MS-012