



Features

- Green Mode to Support Blue Angel requirement.
- Low start-up current (50uA typical)
- Low operating current 6mA
- Low standby power 0.5W
- Pin-for-pin compatible with UC384X
- Current Mode operation up to 500 KHz
- Under voltage lock out (UVLO)

Description

The SL384XG family of control ICs are Green Mode PWM Controller and are pin-for-pin replacement of the industry standard UC3842 series of devices. The high output current drive capability of 1A combined with low start-up current make it an ideal PWM Controller where high efficiency is required. The circuit is more completely specified to guarantee all parameters impacting power supply manufacturing tolerances.

Features

- Off-line Converters
- DC-DC Converters
- DVD/STB Power Supply
- Power Adapter
- CRT Monitoring Power Supply

Pin Configuration – Top View

PDIP (N)

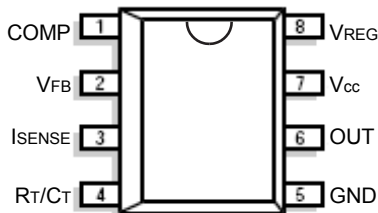

8L SOIC (D8)

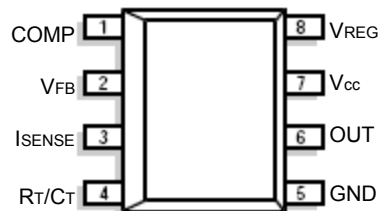

Ordering Information

SL384XG D8 13

Circuit Type: _____
Current Mode Controller (See Table A)

Package Style: _____
D8 = 8 Pin Plastic SOIC
N = 8 Pin Plastic DIP

Packaging Option:
T = Tube
13 = Tape and Reel (13" Reel Dia)
TH = Tube (0 to 125°C)

Table A

Model	V _{CC} (min)	V _{CC} (on)	Duty Cycle Type	I _{cc}
SL3842G	10	16	97%	0.5 mA
SL3843G	7.6	8.4	97%	0.3 mA
SL3844G	10	16	49.5%	0.5 mA
SL3845G	7.6	8.4	49.5%	0.3 mA



Functional Block Diagram

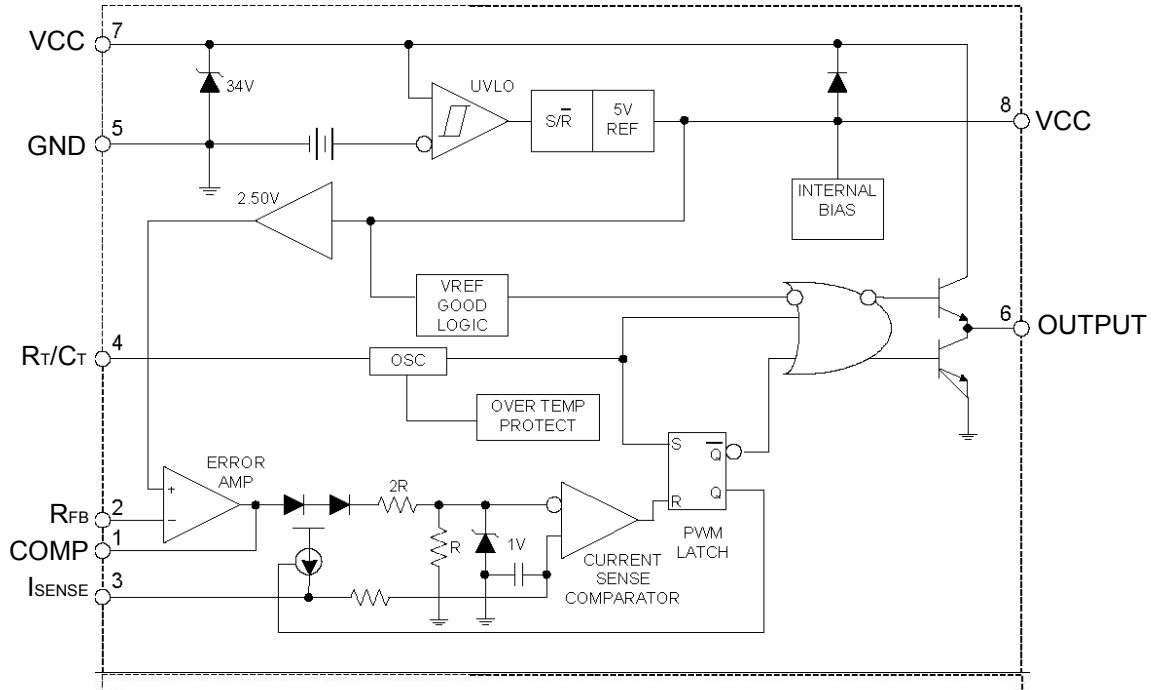

Figure 1. Block Diagram of the SL3842/3/4/5G

Pin Function Description

Pin Number	Function	Description
1	COMP	This pin is the error amplifier output. Typically used to provide loop compensation to maintain V_{FB} at 2.5 V.
2	V_{FB}	Inverting input of the error amplifier. The non-inverting input is a trimmed 2.5 V bandgap reference.
3	Current Sense	A voltage proportional to inductor current is connected to the input. The PWM uses this information to terminate the gate drive of the output.
4	R_T/C_T	Oscillator frequency and maximum output duty cycle are set by connecting a resistor (R_T) to V_{REG} and a capacitor (C_T) to ground. Pulling this pin to ground or to V_{REG} will accomplish a synchronization function.
5	GND	Circuit common ground, power ground, and IC substrate.
6	Output	This output is designed to directly drive a power MOSFET switch. This output can sink or source peak currents up to 1A. The output for the SL3844/5G switches at one-half the oscillator frequency.
7	V_{CC}	Positive supply voltage for the IC.
8	V_{REG}	This 5 V regulated output provides charging current for the capacitor C_T through the resistor R_T .

**Absolute Maximum Ratings**

Parameter	Symbol	Rating	Unit
Supply Voltage ($I_{CC} < 30$ mA)	V_{CC}	Self-Limiting	V
Supply Voltage (Low Impedance Source)	V_{CC}	30	V
Output Current	I_{OUT}	± 1	A
Output Energy (Capacitive Load)		5	μ J
Analog Inputs (Pin 2, Pin 3)		-0.3 to 6.3	V
Error Amp Sink Current		20	mA
Maximum Power Dissipation	PD		
	8L SOIC		460 mW
	8L PDIP		1000 mW
Maximum Junction Temperature	T_J	150	$^{\circ}$ C
Operating Temperature		-40 to 85	$^{\circ}$ C
Storage Temperature Range	T_{STG}	-65 to 150	$^{\circ}$ C
Lead Temperature, Soldering 10 Seconds	T_L	+300	$^{\circ}$ C

Stresses greater than those listed under ABSOLUTE MAXIMUM RATINGS may cause permanent damage to the device. This is a stress rating only and functional operation of the device at these or any other conditions above indicated in the operational sections of this specification is not implied. Exposure to absolute maximum rating conditions for extended periods may affect reliability.

Recommended Conditions

Parameter	Symbol	Rating	Unit
Supply Voltage	V_{CC}		
SL3842G, 44G		15	V
SL3843G, 45G		10	V
Oscillator	fsc	500	kHz

Typical Thermal Resistances

Package	θ_{JA}	θ_{JC}	Typical Derating
8L PDIP	95 $^{\circ}$ C/W	50 $^{\circ}$ C/W	10.5 mW/ $^{\circ}$ C
8L SOIC	175 $^{\circ}$ C/W	45 $^{\circ}$ C/W	5.7 mW/ $^{\circ}$ C



Electrical Characteristics

Electrical characteristics are guaranteed over full junction temperature range(-40 to 85°C). Ambient temperature must be derated based on power dissipation and package thermal characteristics. The conditions are: $V_{CC} = 15\text{ V}$, $R_T = 10\text{ k}\Omega$, and $C_T = 3.3\text{ nF}$, unless otherwise stated.

Parameter	Symbol	Test Condition	Min.	Typ.	Max.	Unit
5 V Regulator						
Output Voltage	V_{REG}	$T_J = 25^\circ\text{C}$, $I_{REG} = 1\text{ mA}$	4.95	5.00	5.05	V
Line Regulation	PSRR	$12\text{ V} \leq V_{CC} \leq 25\text{ V}$		4	15	mV
Load Regulation		$1 \leq I_{REG} \leq 20\text{ mA}$		4	15	mV
Temperature Stability ¹	TC_{REG}			0.2	0.4	mV/°C
Total Output Variation ¹		Line, load, temperature	4.90		5.10	V
Short Circuit Current	I_{SC}			-100	-180	mA
2.5 V Internal Reference						
Nominal Voltage	V_{FB}	$T = 25^\circ\text{C}$; $I_{REG} = 1\text{ mA}$	2.45	2.50	2.55	V
Line Regulation	PSRR	$12\text{ V} \leq V_{CC} \leq 25\text{ V}$		4	15	mV
Load Regulation		$1 \leq I_{REG} \leq 20\text{ mA}$		4	15	mV
Temperature Stability ¹	TC_{VFB}			0.2	0.4	mV/°C
Total Output Variation ¹		Line, load, temperature	2.450	2.500	2.550	V
Long-term Stability ¹		Over 1,000 hrs at 125°C		2	12	mV
Oscillator						
Initial Accuracy	f_{OSC}	$T_J = 25^\circ\text{C}$	47	52	57	kHz
Voltage Stability		$12\text{ V} \leq V_{CC} \leq 25\text{ V}$		0.2	1	%
Temperature Stability ¹	TC_T	$T_{MIN} \leq T_J \leq T_{MAX}$		2		%
Amplitude	f_{OSC}	$V_{RT,CT}$ peak-to-peak		1.7		V
Upper Trip Point	V_H			2.9		V
Lower Trip Point	V_L			1.3		V
Sync Threshold	V_{SYNC}		400	600	800	mV
Discharge Current	I_D		8.5	9.5	10.5	mA
Duty Cycle Limit		$R_T = 680\ \Omega$, $C_T = 5.3\text{ nF}$, $T_J = 25^\circ\text{C}$	46	50	52	%

**Electrical Characteristics (cont'd)**

Electrical characteristics are guaranteed over full junction temperature range(-40 to 85°C). Ambient temperature must be derated based on power dissipation and package thermal characteristics. The conditions are: $V_{CC} = 15\text{ V}$, $R_T = 10\text{ k}\Omega$, and $C_T = 3.3\text{ nF}$, unless otherwise stated. To override UVLO, V_{CC} should be raised above 17 V prior to test.

Parameter	Symbol	Test Condition	Min.	Typ.	Max.	Unit
Error Amplifier						
Input Voltage	V_{FB}	$T_J = 25^\circ\text{C}$	2.45	2.50	2.55	V
Voltage Gain	A_{VOL}	$2 \leq V_{COMP} \leq 4\text{ V}$	65	90		dB
Power Supply Rejection Ratio	PSRR	$12 \leq V_{CC} \leq 25\text{ V}$	60	70		dB
Output Sink Current	I_{COMPL}	$V_{FB} = 2.7\text{ V}$, $V_{COMP} = 1.1\text{ V}$	6	10		mA
Output Source Current	I_{COMPH}	$V_{FB} = 2.3\text{ V}$, $V_{COMP} = 5\text{ V}$	-0.5	-0.8		mA
Output Swing High	V_{COMPH}	$V_{FB} = 2.3\text{ V}$, $R_L = 15\text{ k}\Omega$ to Ground	5	7		V
Output Swing Low	V_{COMPL}	$V_{FB} = 2.7\text{ V}$, $R_L = 15\text{ k}\Omega$ to Pin 8		0.7	1.1	V
Current Sense Comparator						
Transfer Gain ^{2,3}	A_{VCS}	$-0.2 \leq V_{SENSE} \leq 0.8\text{ V}$	2.85	3.0	3.15	V/V
I_{SENSE} Level Shift ²	V_{LS}	$V_{SENSE} = 0\text{ V}$		1.5		V
Maximum Input Signal ²		$V_{COMP} = 5\text{ V}$	0.9	1	1.1	V
Power Supply Rejection Ratio	PSRR	$12 \leq V_{CC} \leq 25\text{ V}$		70		dB
Input Bias Current	I_{BIAS}			-3	-10	μA
Propagation Delay to Output ¹	t_{PD}			85	150	ns
Output						
Output Low Level	V_{OL}	$I_{SINK} = 20\text{ mA}$		0.2	0.4	V
	V_{OL}	$I_{SINK} = 200\text{ mA}$		1.4	2.2	V
Output High Level	V_{OH}	$I_{SOURCE} = 20\text{ mA}$	13	13.5		V
	V_{OH}	$I_{SOURCE} = 200\text{ mA}$	12	13		V
Rise Time ¹	t_R	$C_L = 1\text{ nF}$		150	250	ns
Fall Time ¹	t_F	$C_L = 1\text{ nF}$		50	150	ns
Housekeeping						
Start-up Threshold	$V_{CC(on)}$	SL3842G/44G	15	16	17	V
		SL3843G/45G	7.8	8.4	9.0	V
Minimum Operating Voltage After Turn On	$V_{CC(min)}$	SL3842G/44G	8.5	10	11.5	V
		SL3843G/45G	7.0	7.6	8.2	V
Output Low Level in UV State Over-Temperature Shutdown ⁴	V_{OUV} T_{OT}	$I_{SINK} = 20\text{ mA}$, $V_{CC} = 6\text{ V}$		1.5 155	2.0	V $^\circ\text{C}$

**Electrical Characteristics** (cont'd)

Electrical characteristics are guaranteed over full junction temperature range(-40 to 105°C). Ambient temperature must be derated based on power dissipation and package thermal characteristics. The conditions are: $V_{CC} = 15\text{ V}$, $R_T = 10\text{ k}\Omega$, and $C_T = 3.3\text{ nF}$, unless otherwise stated. To override UVLO, V_{CC} should be raised above 17 V prior to test.

Parameter	Symbol	Test Condition	Min.	Typ.	Max.	Unit
PWM						
Maximum Duty Cycle	D_{max}	SL3842G/43G	94	96		%
Minimum Duty Cycle	D_{min}	SL3842G/43G			0	%
Maximum Duty Cycle	D_{max}	SL3844G/45G	46	48	50	%
Minimum Duty Cycle	D_{min}	SL3844G/45G			0	%
Supply Current						
Start-up Current	I_{CC}	3842/4, $V_{FB} = V_{SENSE} = 0\text{ V}$, $V_{CC} = 14\text{ V}$		50	80	μA
		3843/5, $V_{FB} = V_{SENSE} = 0\text{ V}$, $V_{CC} = 7.7\text{ V}$		30	80	μA
Standby Operating Supply Current	I_{CC}			6		mA
Operating Current	I_{CC}	$V_{FB} = 0$, $V_{CS} = 0$, $C_T = 1\text{ nF}$		8		mA
V_{CC} Zener Voltage	V_Z	$I_{CC} = 25\text{ mA}$	30	34		V

Notes:

1. This parameter is not 100% tested in production.
2. Parameter measured at trip point of PWM latch.
3. Transfer gain is the relationship between current sense input and corresponding error amplifier output at the PWM latch trip point and is mathematically expressed as follows:

$$A = \frac{\Delta I_{COMP}}{\Delta V_{SENSE}}; -0.2 \leq V_{SENSE} \leq 0.8\text{ V}$$

4. At the over-temperature threshold, T_{OT} , the oscillator is disabled. The 5 V reference and the PWM stages, including the PWM latch, remain powered.